

## EnviroPod LittaTrap™ FC For Grated Inlet Catch Basins

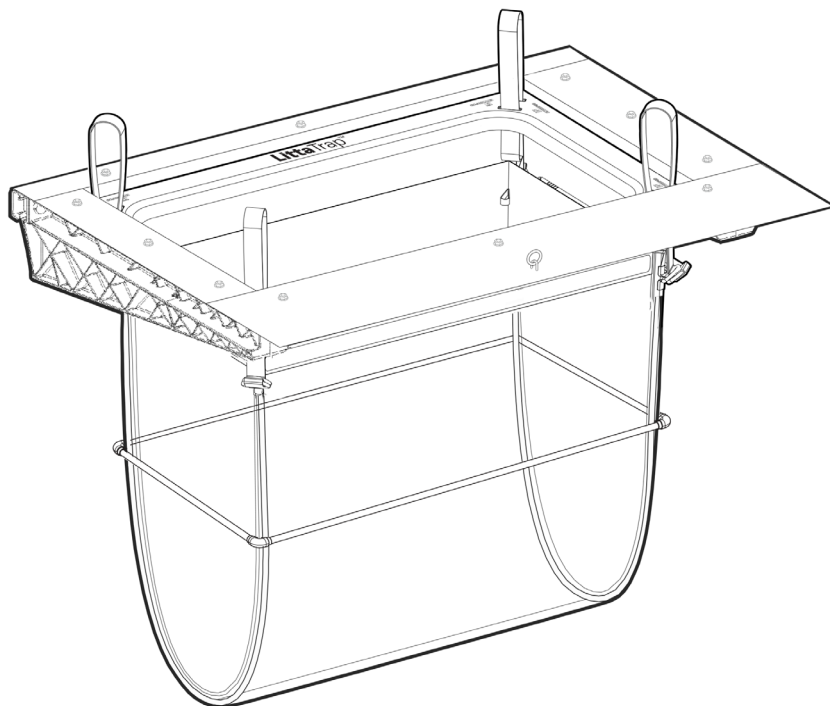

### For installation you will need:

- Measuring Tape
- Box Knife
- Rotary Hammer Drill and 3/8" (10mm) Masonry Bit
- Socket Set with 1/2" (13mm) & 11/16" (17mm) Sockets
- Battery Drill/Driver & 5/16" (8mm) Socket Bit



**ENVIROPOD™**

**ENVIROPOD.COM**



## WARNING

It is essential to follow any local or national Occupational Health and Safety Laws when installing or maintaining LittaTrap™ filters. Ensure all required Personal Protection Equipment (PPE) is worn at all times and Traffic Management rules are adhered to.

When maintaining the LittaTrap™ follow all local or national guidelines for manual lifting whenever hand maintenance is actioned.



## SITE SAFETY

We recommend checking your local website for a Site Specific Safety Plan before undertaking any installation.



## HEALTH AND SAFETY

Personal Protection Equipment (PPE) is required when installing or maintaining a LittaTrap™. This will mean long sleeves, long pants, Hi-Viz, and closed shoes.

We also recommend the use of gloves when maintaining the LittaTrap™.

When maintaining the LittaTrap™ by hand it is essential to identify and assess the weight of the captured material before lifting, as weights can vary depending on the filter contents.

For additional advice on the relevant Health and Safety requirements we recommend that you consult your local website.



## MAINTENANCE

All treatment devices require maintenance to remove trapped contaminants and prevent overflow bypass or flooding. Due to the variable nature of stormwater pollution and localised site pollutant loadings, maintenance frequencies vary for different sites and different rainfall characteristics. It is recommended to inspect your LittaTrap™ frequently over the first year of operation to determine seasonal and annual maintenance requirements.

The LittaTrap™ filter should be maintained when it is approximately 2/3 filled with pollutants or if the filter fabric becomes blocked from hydrocarbons, organics or sediment.

Maintenance is carried out by lifting the filter insert out of the frame assembly using 'J' hooks and emptying into a suitable vessel or trailer to be taken away from the site and disposed of appropriately for the contaminants. Please ensure that all care is taken when disposing of litter as the rubbish caught could contain sharp and dangerous objects.

If there are no "J" hooks the bag can be lifted out by the pulling the Filterbag handles. If the filter fabric is clogged, it should be water blasted into a contained vessel prior being fitted back into the frame assembly.

When carrying out maintenance of the LittaTrap™, it is essential to inspect the overflow bypass slots at the top of the filter insert to ensure no pollutants have been caught and may restrict the flow.

If the LittaTrap™ insert is too heavy to lift by hand, it will need to be maintained using a vacuum inductor truck. When cleaning using a vacuum inductor truck it is essential to take care to not damage the bag from the induction boom. Sediment and pollutants should be vacuum inducted until approx 3/4 empty, and then the remainder lifted and emptied by hand.

# SUPPLIED COMPONENTS

Part A – x1  
**Bracket**

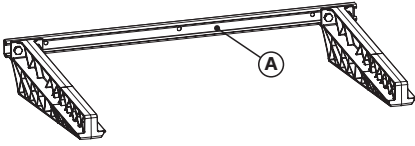

Part B  
**Masonry Anchor Bolts**

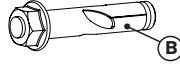

Part E  
**Self Drilling Hexhead Screws**

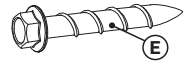

Part C – x1  
**Filterbox**

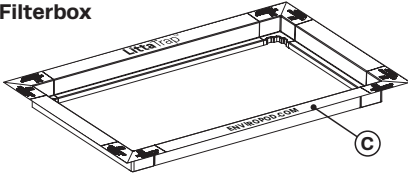

Part F – x1  
**Filterbag**

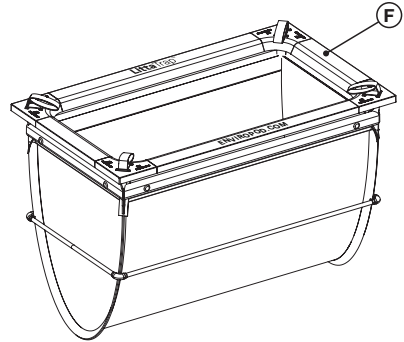

Part D  
**Plastic Seals**

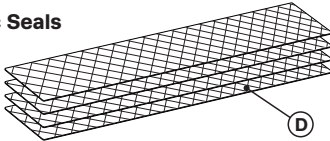

Part G – x1  
**Full Capture Liner**

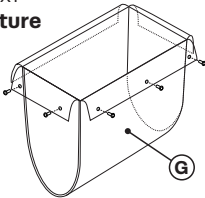

Part H – x1  
**Oil Absorbent Pouches (Optional)**

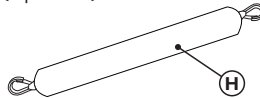

Part I – x1  
**Extension Flap (Optional)**

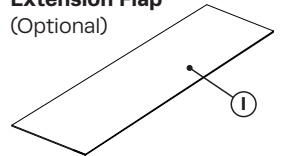

Part J – x1  
**Hinged Vector Port Seal (HVPS)**

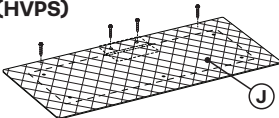

# Hinged Vector Port Seal (HVPS)

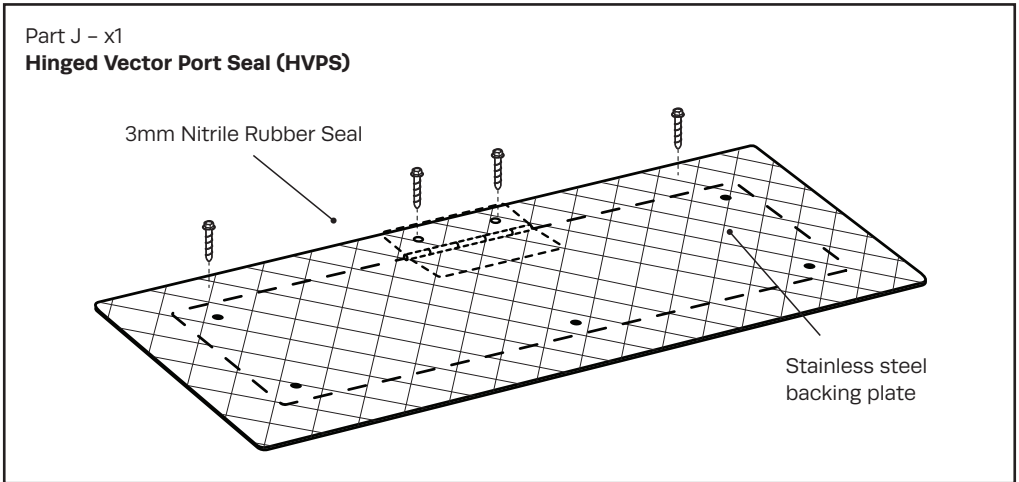
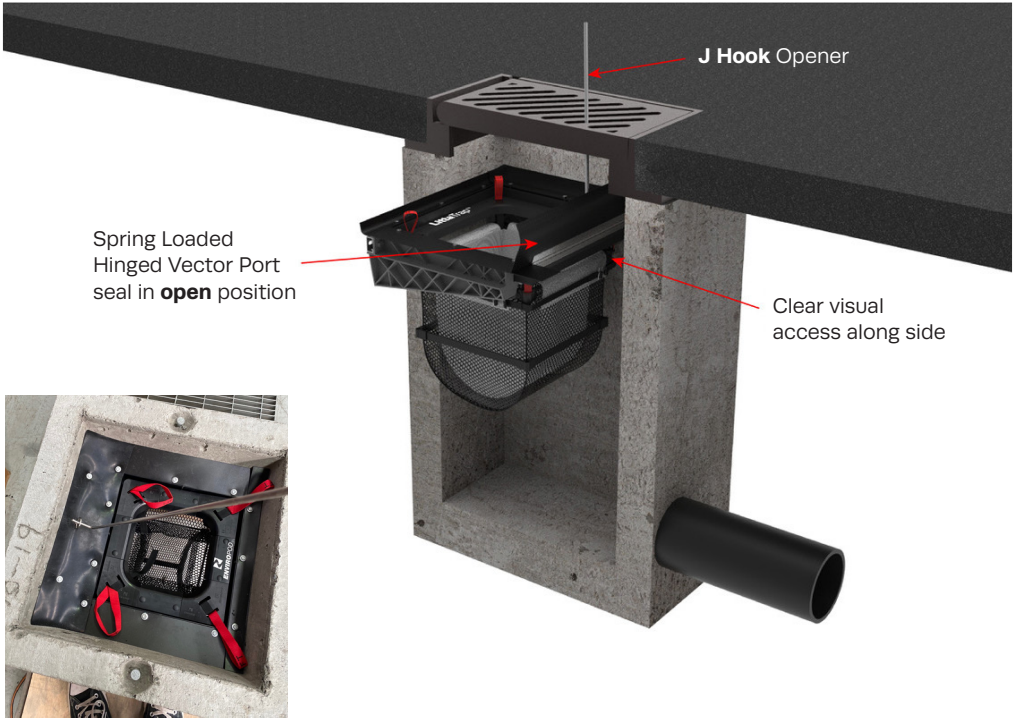

# BRACKET INSTALLATION

01

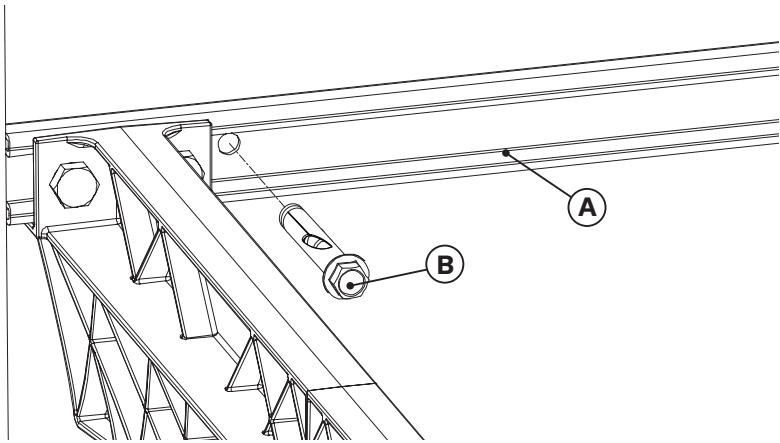
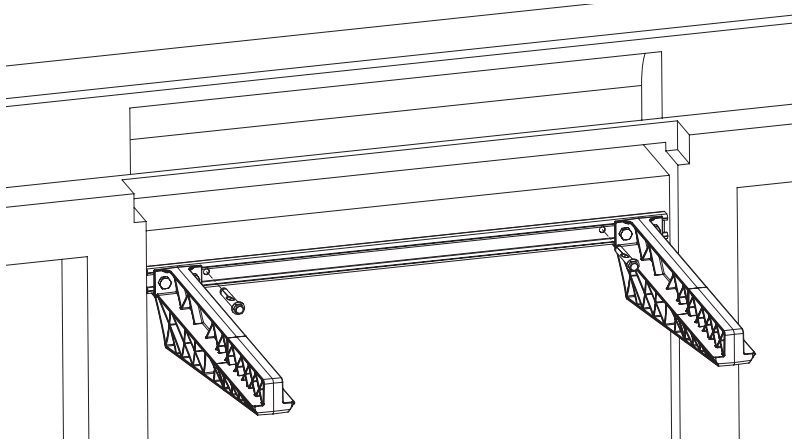

## STEP 01

Place the **Bracket** support at approximately 8" below on the wall under the grate opening or low enough to intercept any kerb entry inlet and ensure it is level. Using the **Masonry Drill**, drill holes into the pit wall using the **Bracket** holes as guidelines.

Insert the **Anchor Bolts** and using the **1/2" (13mm) socket**, secure through the bracket into the wall and tighten to secure.

## FILTERBOX INSTALLATION

02

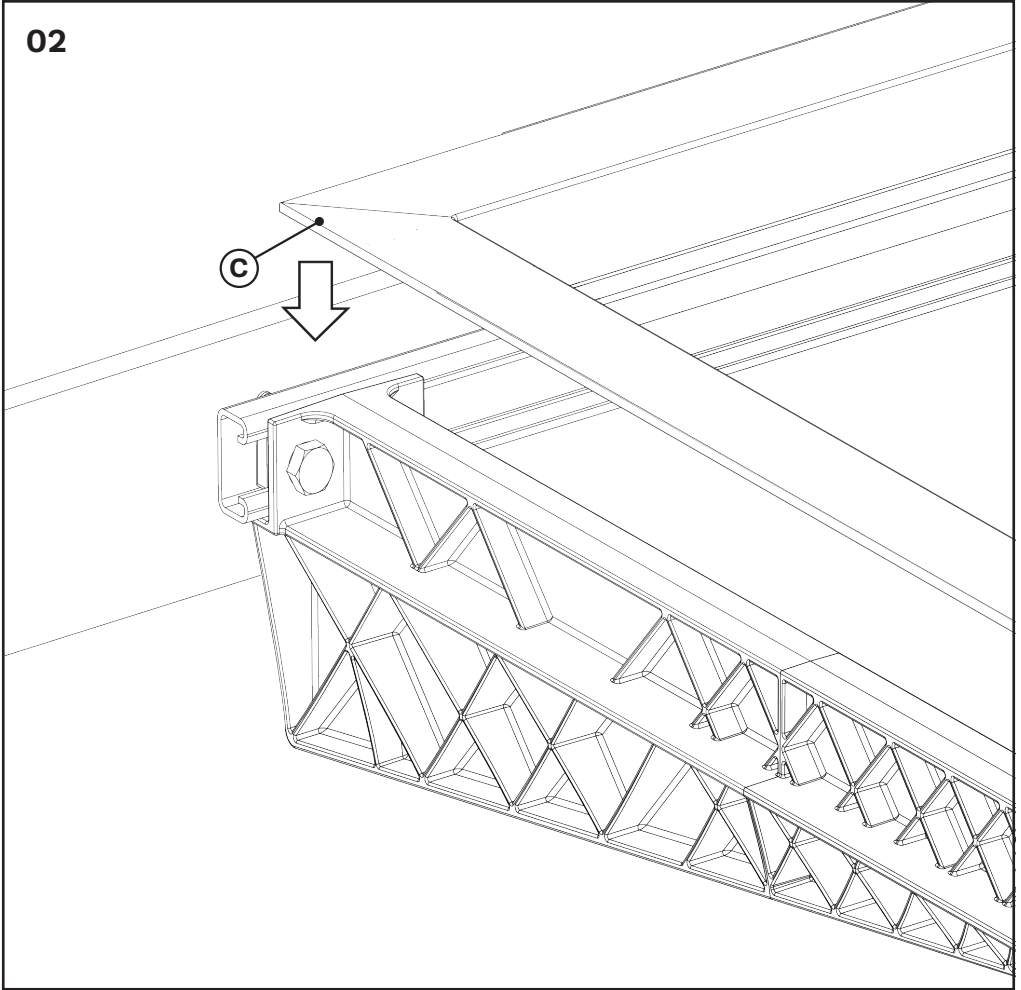

### STEP 02

Place **Filterbox** onto the bracket & position hard against bracket assembly to allow maximum opening for the Hinged Vector Port Seal on the opposite side of the Filterbox.

## FILTERBOX INSTALLATION

03

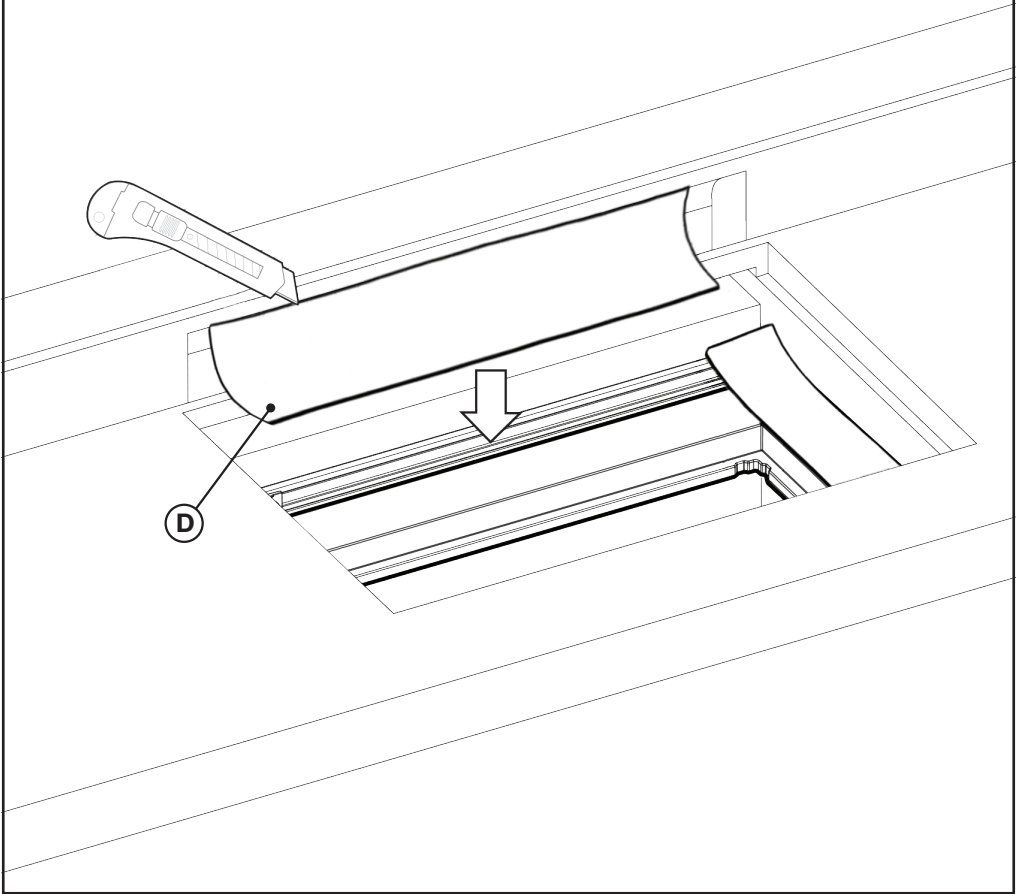

### STEP 03

Measure & trim **Plastic Seals** to size with **Box Knife** to seal gaps between **Filterbox** & pit wall.

Make sure the **Plastic Seals** are flush with the **Filterbox** inside edge and do not overlap the inside face.

## FILTERBOX INSTALLATION

04

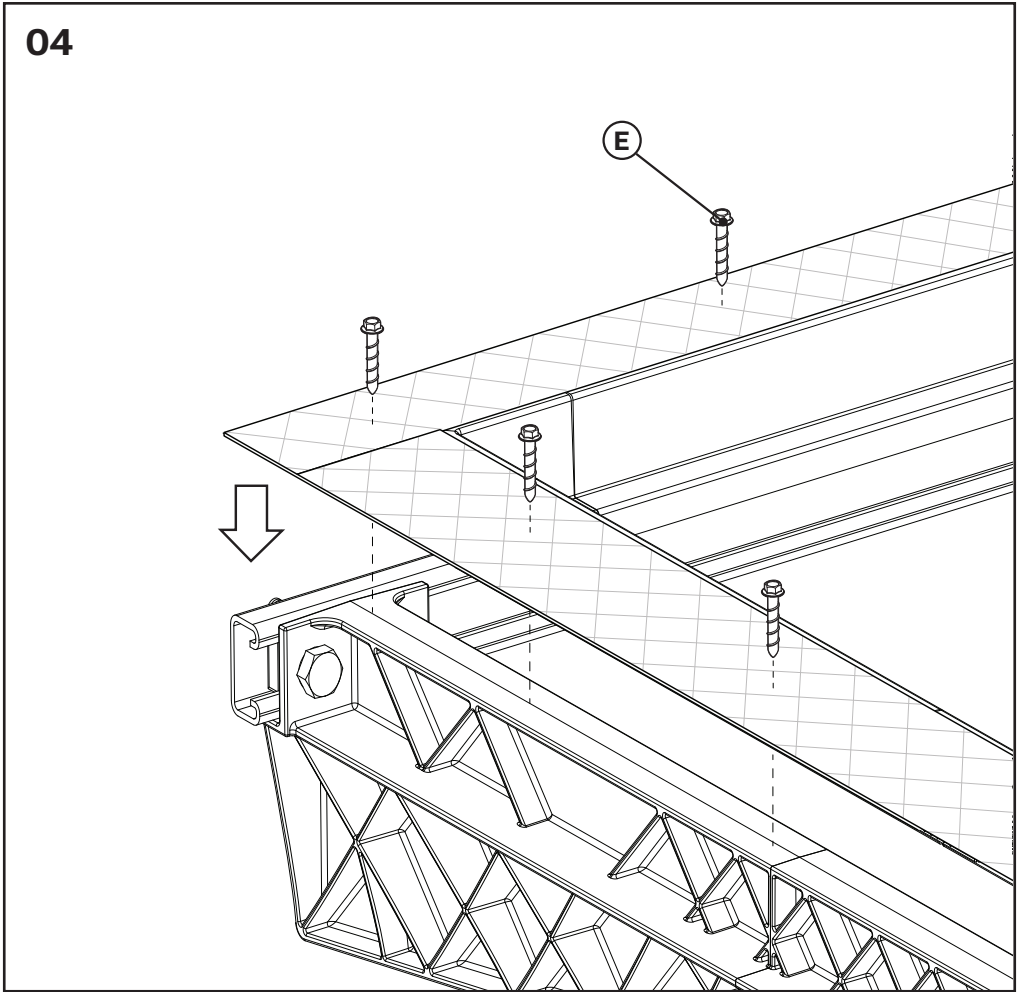

### STEP 04

Secure the unit using the **Battery Drill** to screw the **Self Drilling Screws** through the **Plastic Seals** into the **Filterbox** and into **Bracket**.  
Complete on bracket assembly edge and adjust sides.

## FILTERBOX INSTALLATION

05

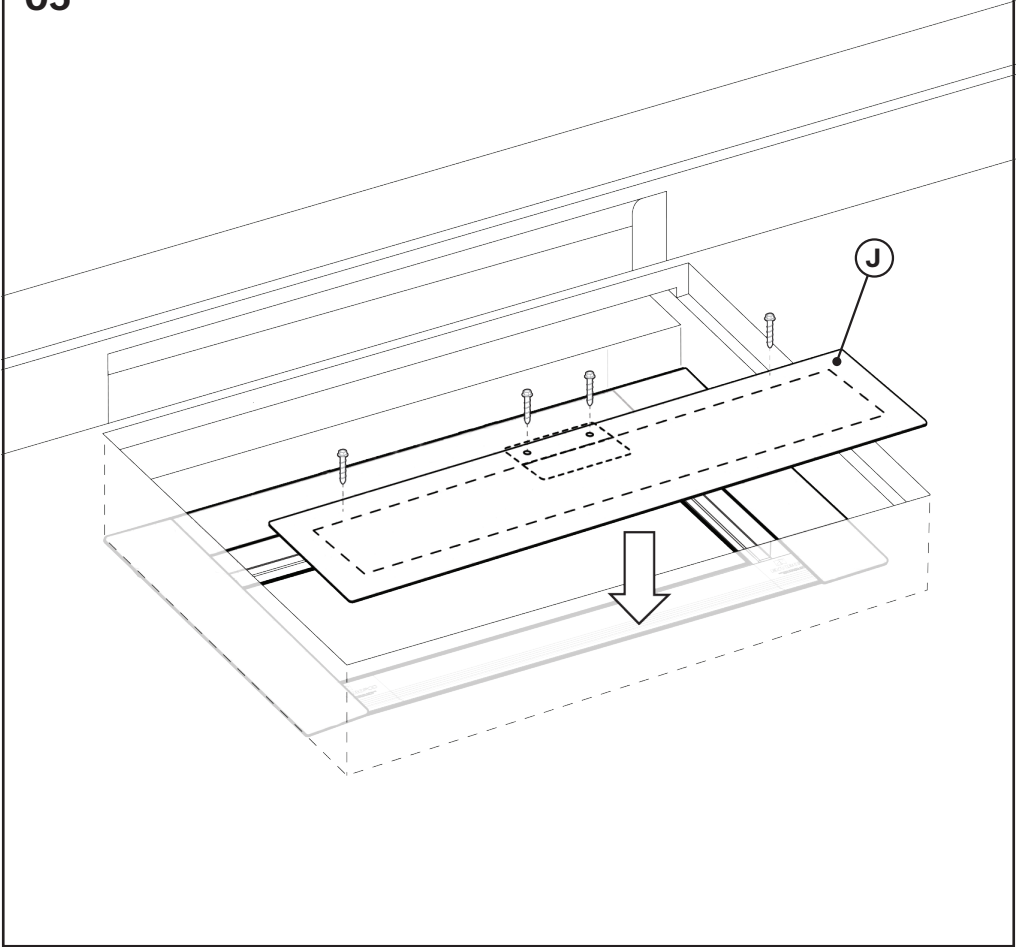

### STEP 05

Screw the **Hinged Vector Portal Seal (HVPS)** to the front face of **Filterbox** and **Bracket** to seal gaps.

# LINERBAG INSTALLATION GUIDE – ALL MODELS

## 06

### 6.1 Insert Full Capture LinerBag

Check LittaTrap & LinerBag size match

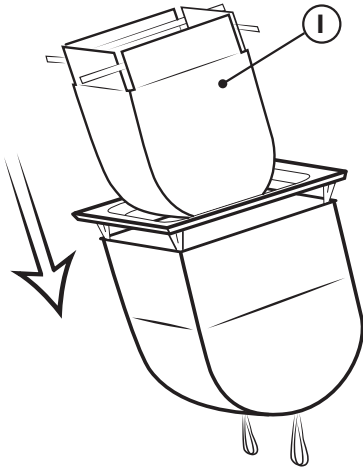

### 6.2 Pull LinerBag flaps through gap

Check LinerBag is not stressed in corners and no gaps

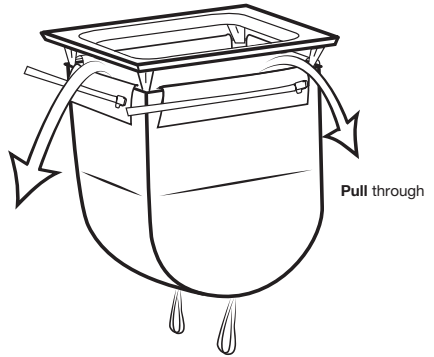

### 6.3 Thread strap 'A' through buckle (all corners)

Arrange straps below plastic corner peg 'X'

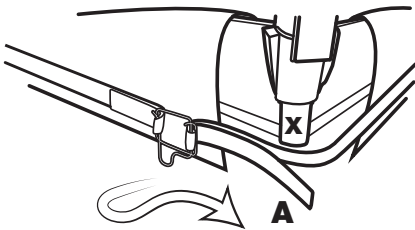

Thread strap through **middle** of buckle  
**around** and **under**, then **pull** tight

### 6.4 Pull LinerBag straps tight all corners

Check straps are below plastic corner pegs (fig 3)

